

Quick Change Tapping Head

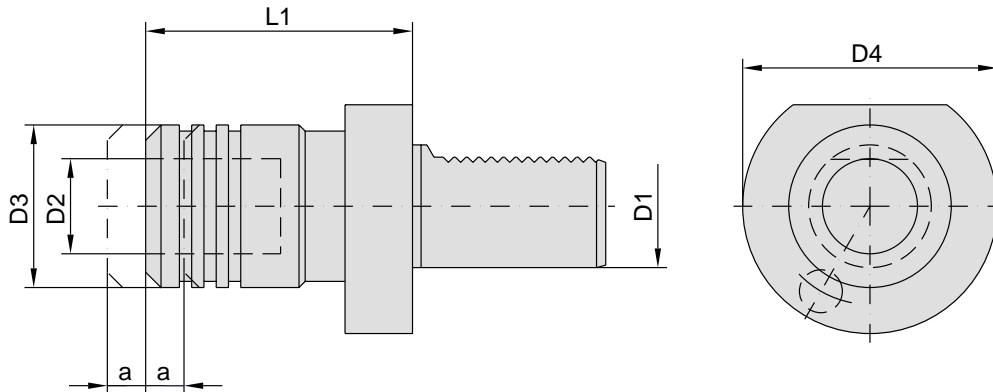

48-GS-... with tension and compression

Item No.	D1	D2 (clamping range)	D3	D4	L1	a	Corresponding Adaptor
48-GS-16x1	16	M3-M12	36	40	52	7.5	WE-1 (170012...)
48-GS-20x1	20	M3-M12	36	50	58	7.5	WE-1 (170012...)
48-GS-26x1	25	M3-M12	36	58	50	7.5	WE-1 (170012...)
48-GS-30x1	30	M3-M12	36	68	62.5	7.5	WE-1 (170012...)
48-GS-30x2	30	M8-M20	53	68	87	12.5	WE-2 (170020...)
48-GS-40x1	40	M3-M12	36	83	62.5	7.5	WE-1 (170012...)
48-GS-40x2	40	M6-M20	53	83	87	12.5	WE-2 (170020...)
48-GS-40x3	40	M14-M33	78	83	122	20	WE-3 (170033...)
48-GS-50x1	50	M3-M12	36	98	70.5	7.5	WE-1 (170012...)
48-GS-50x2	50	M6-M20	53	98	104	12.5	WE-2 (170020...)
48-GS-50x3	50	M14-M33	78	98	108	20	WE-3 (170033...)
48-GS-50x4	50	M22-M48	96	98	122	22.5	WE-4 (170048...)
48-GS-60x2	60	M6-M20	53	123	104	12.5	WE-2 (170020...)
48-GS-60x3	60	M14-M33	78	123	108	20	WE-3 (170033...)
48-GS-60x4	60	M22-M48	96	123	119	22.5	WE-4 (170048...)

Adaptors for Quick Change Tapping Head

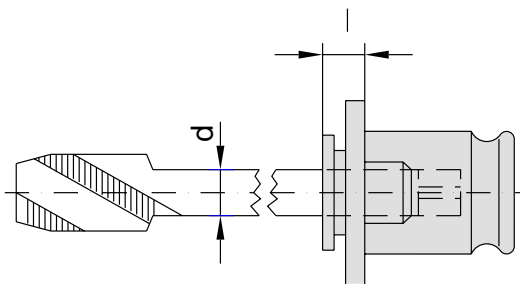

1700...

Item No.	Size	Range	Tap shank dia. ∅	l
170010...[d*10]	WE-0	M1-M10	2.5/2.8/3.5/4/4.5/5/5.5/6/7/8	7
170012...[d*10]	WE-1	M3-M12	2.8/3.5/4/4.5/5/5.5/6/7/8/9/10/11	7
170020...[d*10]	WE-2	M8-M20	7/8/9/10/11/12/14/16	11
170033...[d*10]	WE-3	M14-M33	11/12/14/16/18/20/22/25	14
170048...[d*10]	WE-4	M22-M48	18/20/22/25/28/32/36	42