

Straight drill/milling unit with Coromant Capto™

Please select suitable turret specification from the Machine Type listing!

Typ A: Face mounted

Typ B: O. D. mounted

Ratio = 1:1

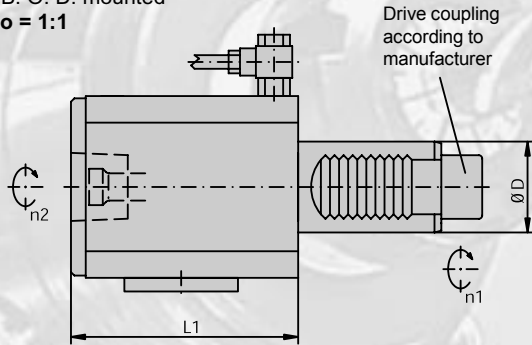

4101... (EC) with external coolant supply

Torque wrench must be used!

Item No.	Turret specification				Clamping System			Dimensions / Data				Drw. No.
	ØD	Turret manufacturer	Typ	Drive coupling	Size			L1	M Nm	Ratio n1:n2	343-830820...	
410103015-30	30	Baruffaldi	A	TOEM 160	C3			76	32	1:1	...N499	
410103016-30	30	Duplomatic	A	DIN 1809	C3			76	32	1:1	...N500	
410103007-30	30	Index G300	B	1-step	C3			76	32	1:1	...N130	
410103013-30	30	Okuma LB 200-M Okuma LT 200-M	B	1-step	C3			67	32	1:1	...N185	
410103025-30	30	Sauter	A	DIN 5480	C3			76	32	1:1	...N1119	
410103006-30	30	Sauter Emco HT-665	B B	DIN 5480	C3			76	32	1:1	...N22	
410103010-30	30	Sauter	A	DIN 5482	C3			76	32	1:1	...N321	
410104068-40	40	Baruffaldi	A	TOEM 200	C4			83	63	1:1	...N501	
410104022-40	40	Duplomatic	A	DIN 1809	C4			100	63	1:1	...N56	
410104095-40	40	Emag	B	DIN 1809	C4			83	63	1:1	...N855	
410104108-40	40	Index G400	B	1-step	C4			83	63	1:1	...N1117	
410104080-40	40	Index V300	B	1-step	C4			83	63	1:1	...N596	
410104064-40	40*	Mazak MP-6100	B	DIN 1809	C4			74	63	1:1	...N86	
410104069-40	40*	Mazak MP-6200	B	DIN 1809	C4			83	63	1:1	...N85	
410104072-40	40*	Mazak SQT-100M(S)	B	DIN 1809	C4			74	63	1:1	...N510	
410104071-40	40*	Mazak SQT-200M(S)	B	DIN 1809	C4			83	63	1:1	...N509	
410104085-40	40	Mori Seiki ZT2500Y	B	DIN1809	C4			83	63	1:1	...N641	
410104041-40	40	Okuma LB 300-M	A	1-step	C4			100	63	1:1	...N8	
410104053-40	40	Okuma LB 400-M	A	1-step	C4			100	63	1:1	...N118	
410104049-40	40	Okuma LT 300-M	B	1-step	C4			74	63	1:1	...N41	
410104061-40	40	Okuma LT 400-M	B	1-step	C4			83	63	1:1	...N288	
410104089-40	40	Okuma LVT 300-M	A	1-step	C4			83	63	1:1	...N755	
410104091-40	40	Okuma LVT 400-M	A	1-step	C4			100	63	1:1	...N757	
410104105-40	40	Sauter	A	DIN 5480	C4			83	63	1:1	...N1072	
410104062-40	40	Sauter Emco HT-690	B B	DIN 5480	C4			83	63	1:1	...N353	
410104019-40	40	Sauter	A	DIN 5482	C4			100	63	1:1	...N176	
410104026-50	50	Baruffaldi	A	TOEM 250	C4			100	63	1:1	...N502	
410104032-50	50	Emag	B	DIN 1809	C4			100	63	1:1	...N1139	
410105032-50	50	Duplomatic	A	DIN 1809	C5			110	100	1:1	...N311	
410105011-50	50	Okuma LB 35II-M	A	2-step	C5			110	100	1:1	...N429	
410105020-50	50	Okuma LU 35-M	A	1-step	C5			110	100	1:1	...N89	
410104030-50	50	Sauter	A	DIN 5480	C4			100	63	1:1	...N1125	
410105051-50	50	Sauter	A	DIN 5480	C5			110	100	1:1	...N1127	
410104031-50	50	Sauter	B	DIN 5480	C4			100	63	1:1	...N1126	
410105013-50	50	Sauter	A	DIN 5482	C5			110	100	1:1	...N92	
410105019-60	60	Duplomatic	A	DIN 1809	C5			110	100	1:1	...N60	
410106003-60	60	Duplomatic	A	DIN 1809	C6			160	200	1:1	...N503	
410105020-60	60	Okuma LU 45-M	A	1-step	C5			110	100	1:1	...N36	
410105013-60	60	Sauter	A	DIN 5482 B25x22	C5			110	100	1:1	...N371	
410106004-60	60	Sauter	A	DIN 5482 B25x22	C6			160	200	1:1	...N504	
410106005-60	60	Sauter	A	DIN 5482 B28x25	C6			160	200	1:1	...N505	

*no VDI standard

Straight drill/milling unit with Coromant Capto™

Please select suitable turret specification from the Machine Type listing!

Typ A: Face mounted

Typ B: O. D. mounted

Ratio = 1:1

Max. coolant pressure = 435 PSI (30 bar)

(Check specified coolant pressure diagram!)

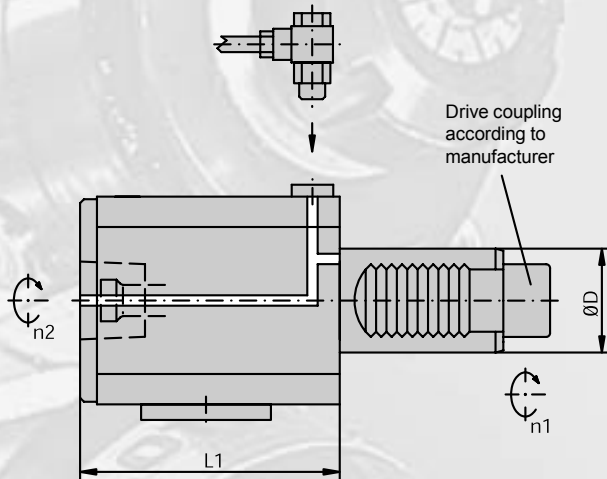

4101... (IC) with internal + external coolant supply

Torque wrench must be used!

Item No.	Turret specification				Clamping System			Dimensions / Data			Coolant Pressure diagram	Drw. No. 343-830820...
	ØD	Turret manufacturer	Typ	Drive coupling	Size			L1	M Nm	Ratio n1:n2		
410103017-30	30	Baruffaldi	A	TOEM 160	C3			76	32	1:1	D01001	...N508
410103008-30	30	Duplomatic	A	DIN 1809	C3			76	32	1:1	D01001	...N166
410103011-30	30	Index G300	B	1-step	C3			76	32	1:1	D01001	...N329
410103023-30	30	Sauter	A	DIN 5480	C3			76	32	1:1	D01001	...N964
410103012-30	30	Sauter Emco HT-665	B B	DIN 5480	C3			76	32	1:1	D01001	...N327
410103005-30	30	Sauter	A	DIN 5482	C3			76	32	1:1	D01001	...N17
410104066-40	40	Baruffaldi	A	TOEM 200	C4			83	63	1:1	D01007	...N153
410104047-40	40	Duplomatic	A	DIN 1809	C4			100	63	1:1	D01007	...N18
410104109-40	40	Index G400	B	1-step	C4			83	63	1:1	D01007	...N1118
410104097-40	40	Index V300	B	1-step	C4			83	63	1:1	D01007	...N889
410104070-40	40*	Mazak MP-6200	B	DIN 1809	C4			83	63	1:1	D01007	...N506
410104027-40	40*	Mazak SQT-200M(S)	B	DIN 1809	C4			83	63	1:1	D01007	...N161
410104086-40	40	Mori Seiki ZT2500Y	B	DIN 1809	C4			83	63	1:1	D01007	...N643
410104029-40	40	Okuma LB 300-M	A	1-step	C4			100	63	1:1	D01007	...N7
410104032-40	40	Okuma LB 400-M	A	1-step	C4			100	63	1:1	D01007	...N294
410104028-40	40	Okuma LT 400-M	B	1-step	C4			83	63	1:1	D01007	...N129
410104090-40	40	Okuma LVT 300-M	A	1-step	C4			83	63	1:1	D01007	...N756
410104092-40	40	Okuma LVT 400-M	A	1-step	C4			100	63	1:1	D01007	...N758
410104099-40	40	Sauter	A	DIN 5480	C4			83	63	1:1	D01007	...N969
410104033-40	40	Sauter Emco HT-690	B B	DIN 5480	C4			83	63	1:1	D01007	...N282
410104013-40	40	Sauter	A	DIN 5482	C4			100	63	1:1	D01007	...N102
410104003-50	50	Baruffaldi	A	TOEM 250	C4			100	63	1:1	D01007	...N421
410105012-50	50	Duplomatic	A	DIN 1809	C5			110	100	1:1	D01007	...N103
410105007-50	50	Okuma LB 35II-M	A	2-step	C5			110	100	1:1	D01007	...N109
410105022-50	50	Okuma LU 35-M	A	1-step	C5			110	100	1:1	D01007	...N427
410104000-50	50	Sauter	A	DIN 5480	C4			100	63	1:1	D01007	...N652
410105048-50	50	Sauter	A	DIN 5480	C5			110	100	1:1	D01007	...N978
410104001-50	50	Sauter	B	DIN 5480	C4			100	63	1:1	D01007	...N653
410105016-50	50	Sauter	A	DIN 5482	C5			110	100	1:1	D01007	...N95
410105025-60	60	Duplomatic	A	DIN 1809	C5			110	100	1:1	D01007	...N380
410106006-60	60	Duplomatic	A	DIN 1809	C6			160	200	1:1	D01000	...N507
410105016-60	60	Okuma LU 45-M	A	1-step	C5			110	100	1:1	D01007	...N234
410105017-60	60	Sauter	A	DIN 5482 B25x22	C5			110	100	1:1	D01007	...N42
410106001-60	60	Sauter	A	DIN 5482 B25x22	C6			160	200	1:1	D01000	...N355
410106000-60	60	Sauter	A	DIN 5482 B28x25	C6			160	200	1:1	D01000	...N163

*no VDI standard