

## Straight drill/milling unit with Coromant Capto™

Suitable for standard turret (not VDI turret)  
Check max. available tool length!

Ratio = 1:1

Max. coolant pressure = 435 PSI (30 bar), 1100 PSI (80 bar)  
(Check specified coolant pressure diagram!)

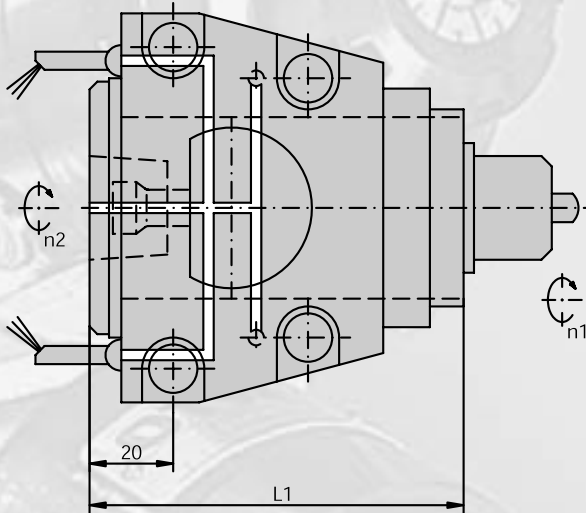

### 4101... (IC) with internal + external coolant supply (max. 435 PSI / 30 bar)

Torque wrench must be used!

Item No.	Turret specification			Clamping System		Dimensions / Data				Coolant	Drw. No.
	∅D	Machine Manufacturer	Max. RPM	Size		L1		M Nm	Ratio n1:n2	Pressure diagram	343-830820... ... N391
410105001-00	-	Mori Seiki SL-400, SL-600	4000	C5		146		100	1:1	D01006	

### 4101... (IC - HP) with internal + external coolant supply (max. 1100 PSI / 80 bar)\*

Torque wrench must be used!

Item No.	Turret specification			Clamping System		Dimensions / Data				Coolant	Drw. No.
	∅D	Machine Manufacturer	Max. RPM	Size		L1		M Nm	Ratio n1:n2	Pressure diagram	343-830820... ... N813
410105004-00	-	Mori Seiki SL-400, SL-600	4000	C5		176		100	1:1	D01013	

\* suitable only for operating in Z-axis!

### 4101... (EC) with external coolant supply only

Torque wrench must be used!

Item No.	Turret specification			Clamping System		Dimensions / Data				Coolant	Drw. No.
	∅D	Machine Manufacturer	Max. RPM	Size		L1		M Nm	Ratio n1:n2	Pressure diagram	343-830820... ... N390
410105000-00	-	Mori Seiki SL-400, SL-600	4000	C5		146		100	1:1		