

## Right angle drill/milling unit with Coromant Capto™ - HIGH PRESSURE -

Suitable for standard turret (not VDI turret)

Check max. available tool length!

Ratio = 1:1

Max. coolant pressure = 1100 PSI (80 bar)

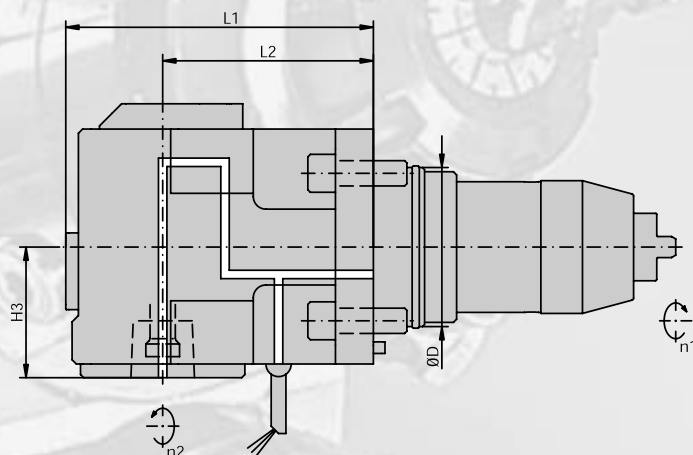

### 4105... (IC - HP) with internal + external coolant supply

Torque wrench must be used!

Item No.	Turret specification			Clamping System	Dimensions / Data					Coolant	Drw. No.
	ØD	Machine manufacturer	Max. RPM		Size	L1	L2	H3 H4	M Nm		
410503003-55	55	Daewoo Puma 200, 230, 240, 250 M Daewoo Puma 1500, 2000, 2500 Y	6000	C3	95	60	45	32	1:1	D01013	343-830820... ... N1148
410504003-65	65	Daewoo Puma 300 M Daewoo Puma 300 MS	6000	C4	124	78	57	63	1:1	D01013	... N736
410504010-65	65	Daewoo Puma MX/TT 2000, 2500	6000	C4	146	100	60	63	1:1	D01013	... N1322
410505017-75	75	Daewoo Puma 400 M/LM	4000	C5	144	85	86	100	1:1	D01013	... N912
410505002-85	85	Daewoo Puma 600, 700 M/LM	4000	C5	145	95	75	100	1:1	D01013	... N709
410503001-55	55	Nakamura Super NTJ, Super NTM Nakamura TW-10 Nakamura TW-20 (16 stations turret) Nakamura WT-150, WT-250 Nakamura WTS-150, WTW-150	6000	C3	89	55	45	32	1:1	D01013	... N1082
410504004-65	65	Nakamura Super NTX, TW-20 Nakamura WT-300	6000	C4	111	65	60	63	1:1	D01013	... N737
410504033-75	75	Nakamura STS-40, STW-40, TW-30	6000	C4	146	100	57	63	1:1	D01013	... N214

### 4105... (EC) with external coolant supply only

Torque wrench must be used!

Item No.	Turret specification			Clamping System	Dimensions / Data					Drw. No.	
	ØD	Machine manufacturer	Max. RPM		Size	L1	L2	H3 H4	M Nm		Ratio n1:n2
410503002-55	55	Daewoo Puma 200, 230, 250 M Daewoo Puma 1500, 2000, 2500 Y	6000	C3	95	60	45	32	1:1		343-830820... ... N884
410504002-65	65	Daewoo Puma 300 M Daewoo Puma 300 MS	6000	C4	124	78	57	63	1:1		... N688
410504009-65	65	Daewoo Puma MX/TT 2000, 2500	6000	C4	146	100	60	63	1:1		... N1321
410505018-75	75	Daewoo Puma 400 M/LM	4000	C5	144	85	86	100	1:1		... N950
410505003-85	85	Daewoo Puma 600, 700 M/LM	4000	C5	145	95	75	100	1:1		... N739
410503000-55	55	Nakamura Super NTJ, Super NTM Nakamura TW-10 Nakamura TW-20 (16 stations turret) Nakamura WT-150, WT-250 Nakamura WTS-150, WTW-150	6000	C3	89	55	45	32	1:1		... N1081
410504001-65	65	Nakamura Super NTX, TW-20 Nakamura WT-300	6000	C4	111	65	60	63	1:1		... N639
410504034-75	75	Nakamura STS-40, STW-40, TW-30	6000	C4	146	100	57	63	1:1		... N396