

## Right angle drill/milling unit with Coromant Capto™

Please select suitable turret specification from the Machine Type listing!

Typ A: Face mounted

Typ B: O. D. mounted

Ratio = 1:1

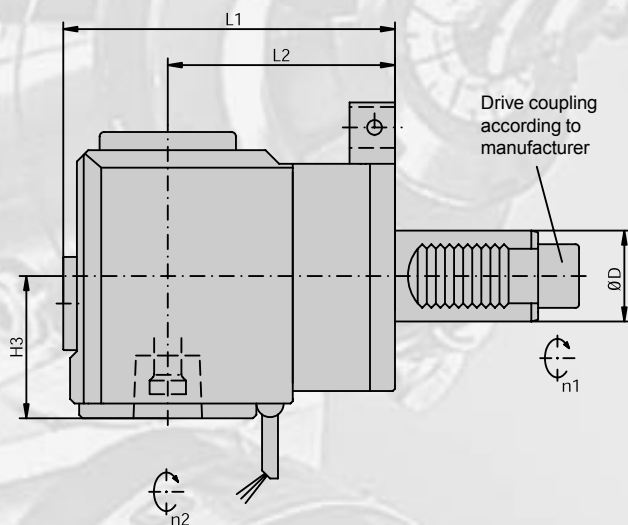

### 4105... (EC) with external coolant supply

Torque wrench must be used!

Item No.	Turret specification				Clamping System			Dimensions / Data					Drw. No.
	ØD	Turret manufacturer	Typ	Drive coupling	Size			L1	L2	H3	M Nm	Ratio n1:n2	
410503000-25	25	Index G200	B	1-step	C3			105	70	45	20	1:1	...N433
410503006-25	25	Traub TNC 42	B	Kegelrad	C3			100	65	45	20	1:1	...N1133
410503051-30	30	Emco HT-665	B	DIN 5480	C3			135	100	45	32	1:1	...N1168
410503009-30	30	Index G300	B	1-step	C3			125	90	45	32	1:1	...N131
410503047-30	30	Okuma LT 200-M	B	1-step	C3			125	90	45	32	1:1	...N1135
410503013-30	30	Sauter (L2=85)	B	DIN 5480	C3			120	85	45	32	1:1	...N378
410503016-30	30	Sauter (L2=100)	B	DIN 5480	C3			135	100	45	32	1:1	...N23
410503033-30	30	Mori Seiki ZT1000Y	B	DIN 1809	C3			100	65	45	32	1:1	...N730
410503036-30	30	Traub TNC 65	B	Kegelrad	C3			110	75	45	32	1:1	...N720
410504117-40	40	Emco HT-690	B	DIN 5480	C4			146	100	60	63	1:1	...N696
410504100-40	40	Index G400	B	1-step	C4			156	110	60	63	1:1	...N604
410504176-40	40	Index V300	B	1-step	C4			129	90	60	63	1:1	...N1166
410504090-40	40*	Mazak MP-6100	B	DIN 1809	C4			154	115	60	63	1:1	...N87
410504089-40	40*	Mazak MP-6200	B	DIN 1809	C4			169	130	60	63	1:1	...N4
410504088-40	40*	Mazak SQT-100M(S)	B	DIN 1809	C4			139	100	60	63	1:1	...N511
410504087-40	40*	Mazak SQT-200M(S)	B	DIN 1809	C4			169	130	60	63	1:1	...N322
410504108-40	40	Mori Seiki ZT2500Y	B	DIN 1809	C4			156	110	60	63	1:1	...N642
410504064-40	40	Okuma LT 300-M	B	1-step	C4			136	90	60	63	1:1	...N40
410504060-40	40	Okuma LT 400-M	B	1-step	C4			146	100	60	63	1:1	...N58
410504135-40	40	Okuma LVT 300-M	A	1-step	C4			116	70	60	63	1:1	...N762
410504137-40	40	Okuma LVT 400-M	A	1-step	C4			116	70	60	63	1:1	...N764
410504121-40	40	Sauter (L2=100)	B	DIN 5480	C4			146	100	60	63	1:1	...N722
410504122-40	40	Sauter (L2=120)	B	DIN 5480	C4			159	120	60	63	1:1	...N723
410505074-50	50*	Mazak MP-6300	B	DIN 1809	C5			224	175	86	100	1:1	...N928
410505087-50	50*	Mazak SQT-300M(S)	B	DIN 1809	C5			209	160	86	100	1:1	...N1131
410504052-50	50	Sauter	B	DIN 5480	C4			156	110	60	63	1:1	...N1108
410505046-60	60	Doosan	B	DIN 5480	C5			174	125	86	100	1:1	...N1140

\*no VDI standard

## Right angle drill/milling unit with Coromant Capto™ - HIGH PRESSURE -

Please select suitable turret specification from the Machine Type listing!

Typ A: Face mounted

Typ B: O. D. mounted

Ratio = 1:1

Max. coolant pressure = 1100 PSI (80 bar)

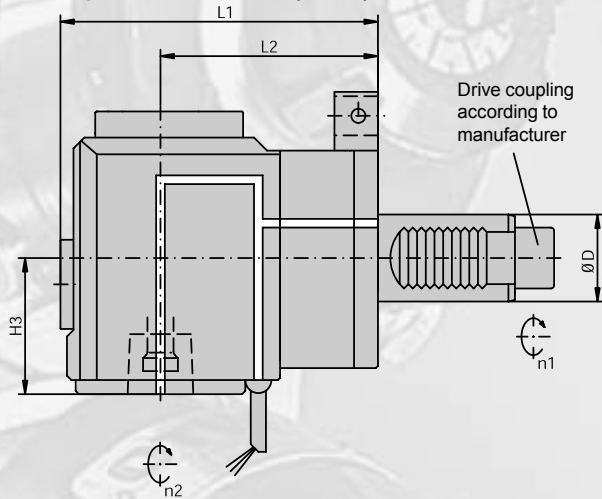

**4105...** (IC - HP) with internal + external coolant supply

Torque wrench must be used!

Item No.	Turret specification				Clamping System			Dimensions / Data					Coolant Pressure diagram	Drw. No.
	ØD	Turret manufacturer	Typ	Drive coupling	Size			L1	L2	H3	M Nm	Ratio n1:n2		
410503001-25	25	Index G200	B	1-step	C3			105	70	45	20	1:1	D01013	343-830820...N434
410503007-25	25	Traub TNC 42	B	Kegelrad	C3			100	65	45	20	1:1	D01013	...N1134
410503052-30	30	Emco HT-665	B	DIN 5480	C3			135	100	45	32	1:1	D01013	...N1169
410503012-30	30	Index G300	B	1-step	C3			125	90	45	32	1:1	D01013	...N330
410503048-30	30	Okuma LT 200-M	B	1-step	C3			125	90	45	32	1:1	D01013	...N1136
410503017-30	30	Sauter (L2=85)	B	DIN 5480	C3			120	85	45	32	1:1	D01013	...N995
410503028-30	30	Sauter (L2=100)	B	DIN 5480	C3			135	100	45	32	1:1	D01013	...N346
410503032-30	30	Mori Seiki ZT1000Y	B	DIN 1809	C3			100	65	45	32	1:1	D01013	...N731
410503046-30	30	Traub TNC 65	B	Kegelrad	C3			110	75	45	32	1:1	D01013	...N1123
410504118-40	40	Emco HT-690	B	DIN 5480	C4			146	100	60	63	1:1	D01013	...N697
410504101-40	40	Index G400	B	1-step	C4			156	110	60	63	1:1	D01013	...N605
410504177-40	40	Index V300	B	1-step	C4			129	90	60	63	1:1	D01013	...N1167
410504091-40	40*	Mazak MP-6100	B	DIN 1809	C4			154	115	60	63	1:1	D01013	...N513
410504092-40	40*	Mazak MP-6200	B	DIN 1809	C4			169	130	60	63	1:1	D01013	...N514
410504079-40	40*	Mazak SQT-100M(S)	B	DIN 1809	C4			139	100	60	63	1:1	D01013	...N323
410504042-40	40*	Mazak SQT-200M(S)	B	DIN 1809	C4			169	130	60	63	1:1	D01013	...N51
410504109-40	40	Mori Seiki ZT2500Y	B	DIN 1809	C4			156	110	60	63	1:1	D01013	...N644
410504082-40	40	Okuma LT 300-M	B	1-step	C4			136	90	60	63	1:1	D01013	...N411
410504031-40	40	Okuma LT 400-M	B	1-step	C4			146	100	60	63	1:1	D01013	...N250
410504136-40	40	Okuma LVT 300-M	A	1-step	C4			116	70	60	63	1:1	D01013	...N763
410504138-40	40	Okuma LVT 400-M	A	1-step	C4			116	70	60	63	1:1	D01013	...N765
410504125-40	40	Sauter (L2=100)	B	DIN 5480	C4			146	100	60	63	1:1	D01013	...N726
410504126-40	40	Sauter (L2=120)	B	DIN 5480	C4			159	120	60	63	1:1	D01013	...N727
410505075-50	50*	Mazak MP-6300	B	DIN 1809	C5			224	175	86	100	1:1	D01013	...N929
410505088-50	50*	Mazak SQT-300M(S)	B	DIN 1809	C5			209	160	86	100	1:1	D01013	...N1132
410504053-50	50	Sauter	B	DIN 5480	C4			156	110	60	63	1:1	D01013	...N1109
410505044-60	60	Doosan	B	DIN 5480	C5			174	125	86	100	1:1	D01013	...N812

\*no VDI standard